



**SPORTELLI PER BANCHI
A TEMPERATURA POSITIVA (+ 5/6 °C)**
si possono fornire a richiesta con chiave

**DOORS FOR POSITIVE
TEMPERATURE (+ 5/6 °C) COUNTERS**
they can be supplied with key upon request

**TÜREN FÜR THEKEN
MIT PLUSTEMPERATUREN (+ 5/6 °C)**
können auf Wunsch mit Schlüssel geliefert werden

**PORTES POUR BANCs
À TEMPÉRATURE POSITIVE (+ 5/6 °C)**
on peut les fournir sur demande avec une clé

**PUERTAS PARA MUEBLES REFRIGERADOS
DE TEMPERATURA POSITIVA (+ 5/6 °C)**
a pedido se pueden suministrar con llave

**PORTAS PARA BALCÕES
DE TEMPERATURA POSITIVA (+ 5/6 °C)**
disponíveis a pedido munidas de chave

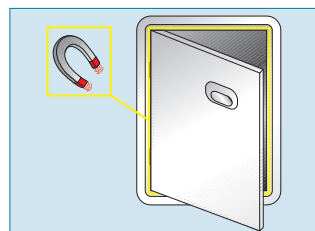

MAG



art. 3000/10

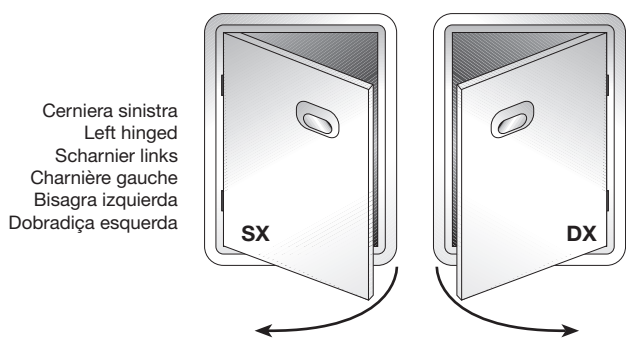

Cerniera sinistra
Left hinged
Scharnier links
Charnière gauche
Bisagra izquierda
Dobradiça esquerda

Cerniera destra
Right hinged
Scharnier rechts
Charnière droite
Bisagra derecha
Dobradiça direita

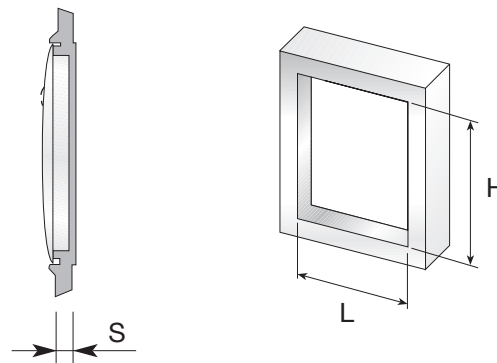

Art. ⁽¹⁾	Art. ⁽²⁾	S	L	H
		(mm)	(mm)	(mm)
3007	-	50	440	235
3005	-	50	440	280
3006	-	50	440	310
3004	3004 MAG	50	440	380
3002	3002 MAG	50	440	440
3001	3001 MAG	50	440	480
3000	3000 MAG	50	440	590
3009	3009 MAG	50	440	720
Sportello orizzontale - Horizontal doors - Horizontale Türen - Portes Horizontales - Puerts Horizontales - Portas horizontais				
3000/10	-	50	590	440

⁽¹⁾ Chiusura con scrochetto
Closure with snap lock
Verschluss mit Türschnapper
Fermeture avec déclic
Cierre con pasador
Fecho com trava de mola

⁽²⁾ Chiusura con guarnizione magnetica
Closure with magnetic seal
Verschluss mit magnetischer Dichtung
Fermeture avec garniture magnétique
Cierre con guarnición magnética
Fecho com junta magnética

Specificare in fase d'ordine la posizione delle cerniere (destra o sinistra)
Please specify the hinge position (left-hand or right-hand side) at purchase order
Bitte bei der Bestellung die Position der Scharniere (rechts oder links) angeben
Spécifier la position des charnières au moment de la commande (droite ou gauche)
En el pedido especificar la posición de las bisagras (derecha o izquierda)
Especificar no pedido a posição das dobradiças (direita ou esquerda)